



TUBE & INDUSTRIAL FIRE SHUTTERS

**TRUSTED FOR 30 YEARS
TO PROTECT THE BUILDINGS
OF THE PAST, AND THE FUTURE**



00 441204 383839 WWW.A1SGROUP.COM
ENQUIRIES@A1SHUTTERS.CO.UK
CONTACT US TODAY

UNIVERSITY OF CAMBRIDGE

Our tube fire shutters protect kitchen serveries and refectories throughout the University of Cambridge



HAMAD INTERNATIONAL AIRPORT

Winner of the 2015 Global Strategic Project of the Year.

A1S MANUFACTURED BOTH TUBE AND INDUSTRIAL RATED FIRE SHUTTERS FOR THIS ICONIC HUB



"DOHA'S INTERNATIONAL AIRPORT IS ARGUABLY THE MOST ARCHITECTURALLY SIGNIFICANT TERMINAL COMPLEX IN THE WORLD, AS WELL AS BEING THE MOST LUXURIOUS."

THE A1S GROUP.

The A1S Group is a leading UK manufacturer, supplier and installer of Tube, Industrial and Radiant Heat Reducing Fire Rated Shutters. We supply and install our fire rated shutters throughout the UK and export globally. Building on our 30 year heritage as quality shutter manufacturers and coupling the highest quality steels with the latest in motor technology, we always meet exacting fire standards without compromising on design aesthetics. Manufacturing shutters with up to a four hour rating to BS EN 1634-1, we offer our UK and International Partners, competitive pricing, flexible lead times, marketing expertise and world class technical support. Our experienced team is committed to providing the latest fire protection technologies with the highest level of customer service. Our winning strategy continues to build and develop long term partnerships with UK trade customers, main contractors and International partners. We all share a passion for protecting the buildings of the future and of course the people using them.

A1S GROUP SECTOR EXPERIENCE

We are acknowledged experts in the manufacture supply and installation of fire shutters for Stadia, Commercial Offices, Extra Care Units and Hospitals, Retail and Shopping Centres, Hotels and Restaurants, Churches, Mosques and Synagogues, Schools and Universities, Museums, Galleries and Heritage Sites, Government and Military Buildings. To date we have completed over ten thousand successful fire shutter projects.

CONTACT US TODAY FOR A WINNING QUOTATION OR TO DISCUSS YOUR LATEST PROJECT.

WWW.A1SGROUP.COM



THE ROYAL ALBERT HALL

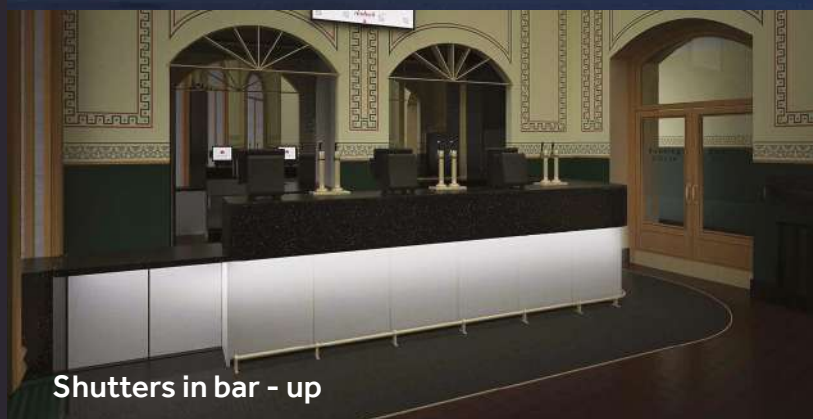

"I HAVE BEEN BUYING... A1S GROUP FIRE RATED SHUTTERS FOR FIFTEEN YEARS. THEY ALWAYS DELIVER WHEN I NEED COMPLIANCE, RELIABILITY AND DISCREET DESIGN."

COOKS OF NORWICH

A1 MANUFACTURE, RADIANT HEAT REDUCING, INDUSTRIAL AND TUBE MOTOR FIRE RATED SHUTTERS. ALL A1 FIRE SHUTTERS ARE MANUFACTURED IN ACCORDANCE WITH THE RELEVANT BS EN STANDARD AND HAVE BEEN TESTED AT WARRINGTON EXOVA. FULL CERTIFICATION AND TESTING DOCUMENTATION IS AVAILABLE ON REQUEST.

RADIANT HEAT REDUCING FIRE SHUTTER SPECIFICATION

Barrel Assembly –

Constructed from steel tube manufactured to BS EN 10219 on a steel shaft and mild steel bearing blocks each end incorporating high speed bearings. Tube and shaft sized according to opening size and door weight.

Curtain –

Exterior and interior constructed from galvanised steel interlocking laths manufactured to BS EN 10346 with a protective zinc coating of 275g/m². Each section is minimum 85mm deep with triple ribbed face for increased rigidity. Each panel is terminated with a hardwearing steel end locks. Bottom of curtain incorporates a special galvanised rolled section.

Lath configuration –

The shutter curtain has a high density rockwool insulated infill.

End Plates –

Formed from minimum 6mm thick mild steel plate to support the barrel and take the weight of the shutters.

Guides –

Constructed from minimum 84mm x 70mm x 3mm thick galvanised steel guide channels, assembly bolted to 100mm x 50mm x 6mm thick steel angle sections.

Hoods –

Manufactured to BS EN 10346 with a protective zinc coating of 275g/m² complete with reinforced brackets as required to suit the shutter width and fire resistance,

Operation –

Via geared electric motor with integral controlled descent mechanism for connection

Radiant heat reducing shutters providing four hours rating



**1000S OF A1
FIRE SHUTTERS
PROTECT UK
SCHOOLS &
HOSPITALS**



A1 physically tests our fire shutters at Warrington Exova

FIRE PROTECTED HEAT REDUCING ROLLER SHUTTER

Key:

- Components supplied by AIS Group
- Structure already in situ
- Requirements by others
- Dimensions
- Notes

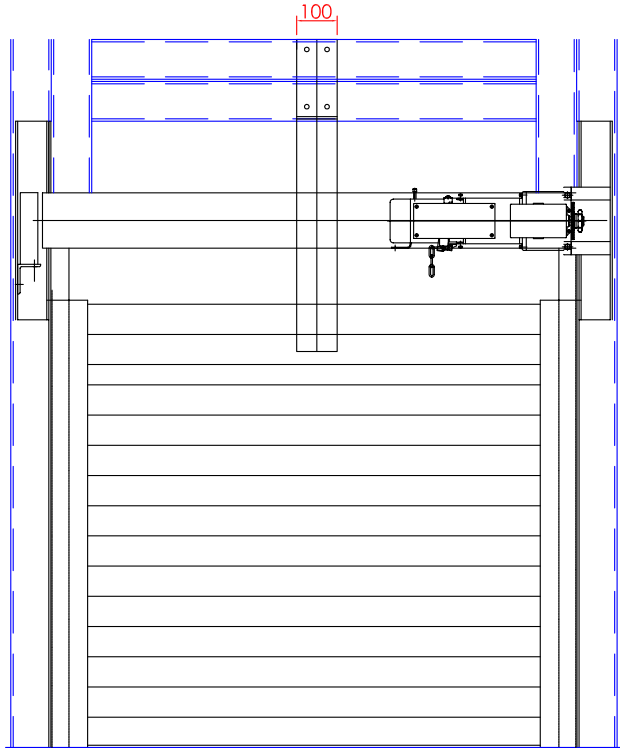

Front Elevation

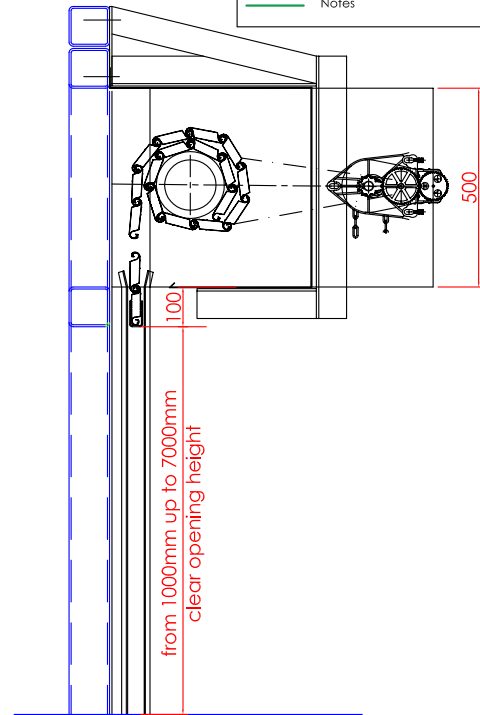

Side Elevation

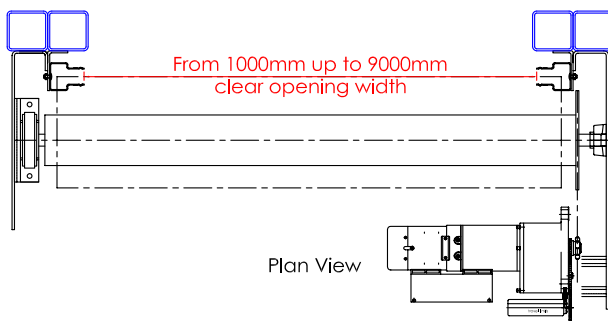

Plan View

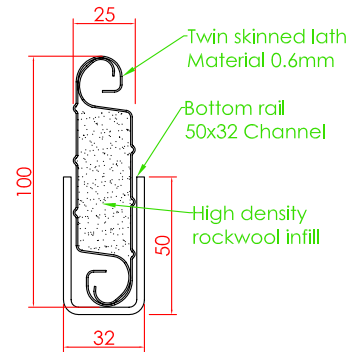

Bottom rail detail

Inclusions:

- JM750 3 Ph Motor
- Auto Reset Solenoid
- Fusible Link Back-Up
- Twin Skinned Lath
- 85mm guide
- Hood
- Push Button Station
- Safety bearing
- Brush Strip to Head & Guides
- Bottom Rubber

Box sizes and fixing details on application due to the bespoke nature of this product

REV	Description	Date
-	First issue	xxx

Description: Fire Protected Heat Reducing Roller Shutter	
Client: xxx	Contract No.: xxx
Project: xxx	Date: xxx

Fire rating:	Up to 120 mins.
Structure:	Masonry/Steel
Finish:	RAL xxx

Drawn By: LCB	
Drawing No.: xxx	

All dimensions in millimetres - DO NOT SCALE

INDUSTRIAL FIRE RATED ROLLER SHUTTERS

It can be linked to the building alarm system with back up fusible link unit, rotary limits, emergency hand chain for raising the shutter and push button starter with open/stop/close controls requiring electrical supply of 400/415 volt, 3 phase, 50 hertz. Electrically operated products are CE marked.

Finish -

Galvanised to BS EN 10346 with a protective hot dipped zinc coating of 275g/m² finished to a normal spangle, with one coat black primer paint on non- galvanised surfaces. A polyester powder coat paint finish is available at an additional cost

Fire Resistance -

Assessed for up to 4 hours fire resistance, integrity and stability to BS476 part 22 by Exova Warrington Fire, WF Assessment report No 349018. Warrington Fire Manufacturing Assessment report 19528/1B Shutters can be manufactured 1HR, 2HR or 4HR rated.

Curtains constructed from a 76mm curved steel scroll laths (18 to 22 swg laths dependent on size) interlocked with steel end locks and galvanised t section bottom rail.

Barrel manufactured from mild steel tube, tube size varies based on the overall width and height of the curtain and the gauge of laths. The tube wall thickness varies dependant on the width of the shutter, the barrels are mounted on bright steel shafts varying from 25mm to 50mm dependant on the overall size of the shutter, the shafts have mild steel bearing blocks at each end incorporating high speed bearings.

Guides constructed from 65mm straight channel galvanised guide mounted on 75mm x 50mm mild steel angle.

Hood Formed from 20swg steel sheet, with the top leg slotted for expansion. Dependant on the fire rating of the shutter (i.e 1HR, 2HR and 4HR) and the size of the opening, the shutter could require a

hood support bracket (see separate chart). Motor Hood Generally an optional extra, but it is a requirement that all shutters electrically operated under 2500mm opening height should be fitted with a motor hood.

The curtains and guide are galvanised steel, angles, barrel and end plates are painted. A paint finish using a polyester powder coating system is available, the colour to a BS 4800 or RAL number subject to availability.

Operation -

Electrically operated 1PH / 3PH – Hand chain override

Release Mechanisms -

Fusible Link
Manual Solenoid
Auto Solenoid

Weight -

35kg/m²



Four Hour Rated Industrial Shutter-

INDUSTRIAL FIRE SHUTTER

Key:

- Components supplied by AIS Group
- Structure already in situ
- Requirements by others
- Dimensions
- Notes

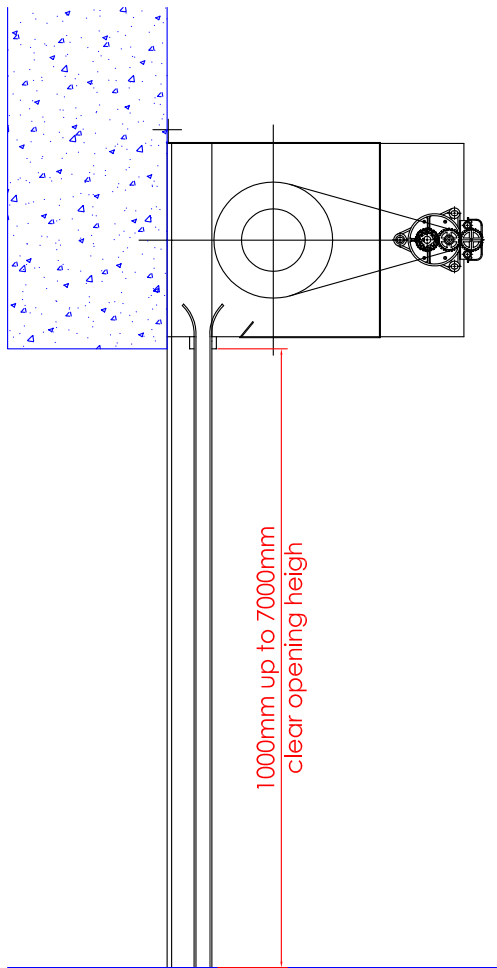

Elevation

Box sizes and fixing details on application due to the bespoke nature of this product

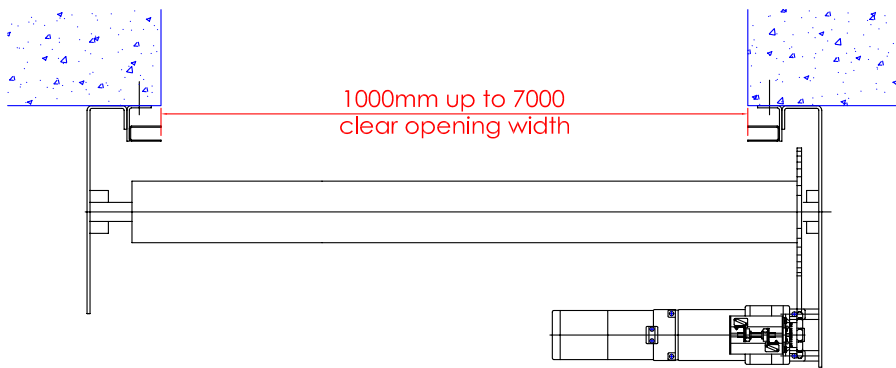

Plan View

Inclusions:

- JM750 3 Ph Motor
- Auto Reset Solenoid
- Fusible Link Back-Up
- 75mm galvanised steel curved lath
- Hood
- Push Button Station
- Safety bearing

REV	Description	Date
-	First issue	xxx

Description: Industrial Fire Shutter	
Client: xxx	Contract No: xxx
Project: xxx	Date: xxx
All dimensions in millimetres - DO NOT SCALE	
Drawn By: LCB	Drawing No: xxx

Fire rating:	Up to 120 mins.
Structure:	Masonry/Steel
Finish:	RAL xxx

TUBE FIRE SHUTTER

All our fire shutters are manufactured and produced in accordance with the parameters and technical respects indicated within the specification, which was submitted to the Warrington Fire Research Establishment. The shutters are constructed to Warrington Fire Research Centre WARRES No 192095, the test is in accordance with clause 8 of BSEN 1634-1 : 2008

Warrington Fire CERTIFIRE certificate WARRES No CF765A

Curtains constructed from a 50mm flat / 76mm curved steel scroll laths interlocked with steel end locks and galvanised t section bottom rail.

Barrel manufactured from mild steel tube, tube size varies based on the overall width and height of the curtain and the gauge of laths. The tube wall thickness varies dependant on the width of the shutter, the barrels are mounted on bright steel shafts varying from 18mm to 30mm dependant on the overall size of the shutter, the shafts have mild steel bearing blocks at non geared end and tubular motor at the geared end. Guides constructed from 50mm straight channel

galvanised guide mounted on 50mm x 50mm mild steel angle(minimum).

Hood formed from 20 swg steel sheet, with the top leg slotted for expansion. Dependant on the fire rating of the shutter (i.e 1HR, 2HR) and the size of the opening, the shutter could require a hood support bracket.

The curtains and guide are galvanised steel, angles, barrel and end plates are painted. A paint finish using a polyester powder coating system is available, the colour to a BS 4800 or RAL number subject to availability.

Operation -

Electrically operated 1PH

Release Mechanisms -

Fire relay, key switch & fusible link (requires maintained supply, battery back up needed if no maintained supply), fusible link if no fire alarm.



FLAMESHIELD 120 TUBE FIRE SHUTTER

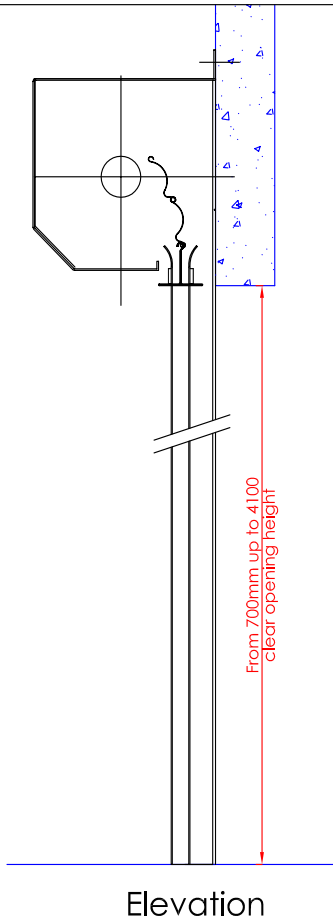

Standard Box Sizes for Tube Motor Fire Shutters

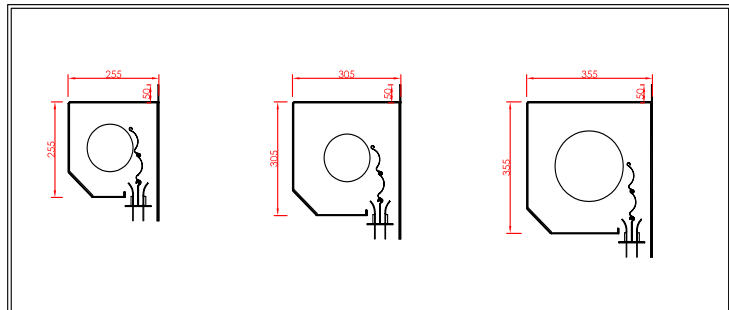

Guide Fixing Options

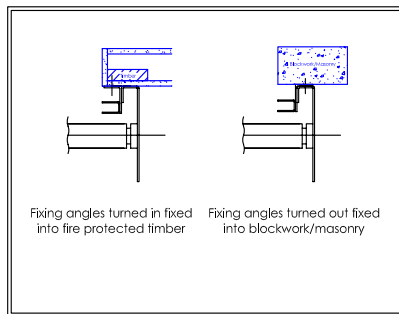

Box Fixing

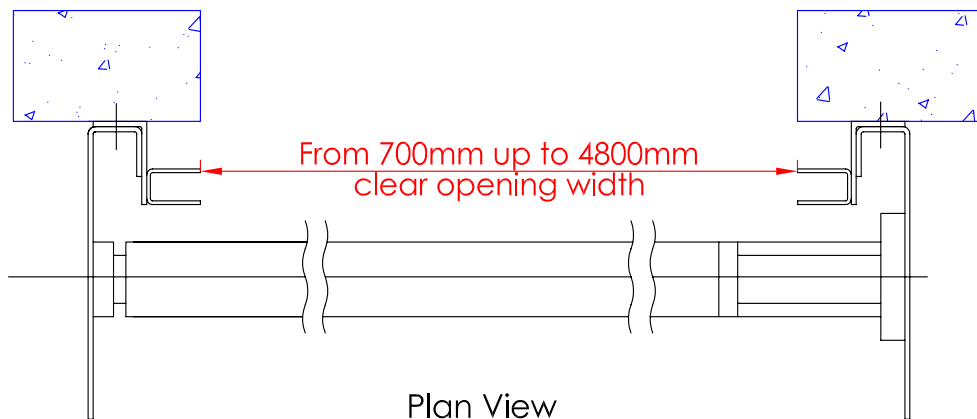
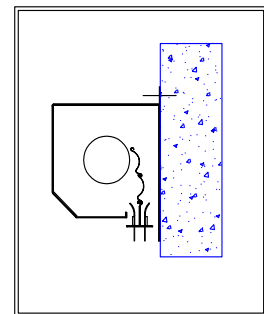

Inclusions:

- Lath curved 75mm solid galv.
- Ordinary/Reverse coil
- 24V Tube Motor
- Key Switch
- Manual Override
- Battery back-up c/w bracket
- P.P.C - RAL xxxx

Exclusions:

- Audio visual panel
- Repeater panel

REV	Description	Date
-	First issue	xxx

Description: Flameshield 120 Fire Shutter
Client: XXX
Project: XXX
All dimensions in millimetres - DO NOT SCALE

Fire rating: Up to 120 mins.
Structure: Masonry/Steel
Finish: RAL xxx
Contract No: XXX
Date: XXX
Drawn By: LCB
Drawing No: XXX





The London Olympic Stadium benefits from 66 A1S Group Industrial Fire Shutters

Manchester City's Etihad stadium, has A1S Group shutters installed within its concourse & at the club superstore



FIRE RATED SOLUTION FOR LOGISTICS GIANT DHL'S CONVEYOR BELT



ELECTRICAL CONTROL EQUIPMENT



Key switch



Battery Back Up



Fire Relay Unit



Push button station



Audio Visual Warning Unit



WE HAVE INSTALLED THOUSANDS OF FIRE RATED SHUTTERS AND CONTINUE TO BE SPECIFIED BECAUSE OF OUR VALUE, QUALITY AND COMPLIANCE. CONTACT US TODAY TO DISCUSS YOUR LATEST PROJECT.



TUBE AND INDUSTRIAL FIRE SHUTTERS

Contact our UK and international sales team
TODAY for a fast and winning quotation
for your next project. We are always looking for
new projects and partnerships.



Fire Curtains | Smoke Curtains | Fire Shutters | Roller Shutters | Industrial Shutters

A1S GROUP CONTACT US TODAY

Jackson Works, Raikes Lane Industrial Estate, | Raikes Lane, Bolton, BL3 2NH, United Kingdom

Web www.a1shutters.co.uk | Mail sales@a1shutters.co.uk

Tel: 01204 383839 Fax: 01204 381686

